



Extruded aluminium security shutter suitable for commercial sites & shop-front applications, up to 25m². Punched (V77) or Perforated (P77) profile slats can be incorporated as required for full or partial vision (see Datasheets 11 & 12).



APPLICATIONS

Commercial sites & shop-front applications, up to 25m². The E77 & V77 can be upgraded to insurance approved Secured by Design status, meeting LPCB LPS1175 (6.0) standard to SR2. Punched (V77) or Perforated (P77) profile slats can be incorporated as required for full or partial vision. (See Datasheets 11 & 12). Suitable for internal or external face or reveal fit.

CURTAIN SLAT

Double skinned extruded aluminium.

Finish: White or Brown as standard. Option to powder coat any RAL / BS colour (surcharge applies).

Visible Face:	77mm
Weight per m ² :	8.5kg
Maximum Width:	6500mm
Maximum Area:	25m ²

ENCLOSURE

Roll-formed aluminium box with pressure-moulded aluminium alloy end plates.

Finish: White or Brown as standard. Option to powder coat any RAL / BS colour (surcharge applies).

Plate sizes shown as a guide only and may vary.

BOTTOM SLAT

Extruded aluminium bottom slat with weather seal.

GUIDE CHANNELS

Extruded aluminium guide channels with brush inserts. Width of 70mm, 90mm or 150mm.

Finish: White or Brown as standard. Option to powder coat any RAL / BS colour (surcharge applies).

OPERATION

Electric: Tubular motor & internal rocker or external key switch as standard. Safety brake as appropriate to comply with legislation. Manual override facility & crank handle as required (surcharge applies). Numerous control option variants such as group, remote or mobile phone activation.

Note: Manual operation is available but not common for the E77 as the shutter tends to be used to cover larger openings.

CE compliant to all applicable directives and standards.

Guide Height (mm)	Plate Size (mm)
1650	250
2600	300
4640	360

FRONT FACE

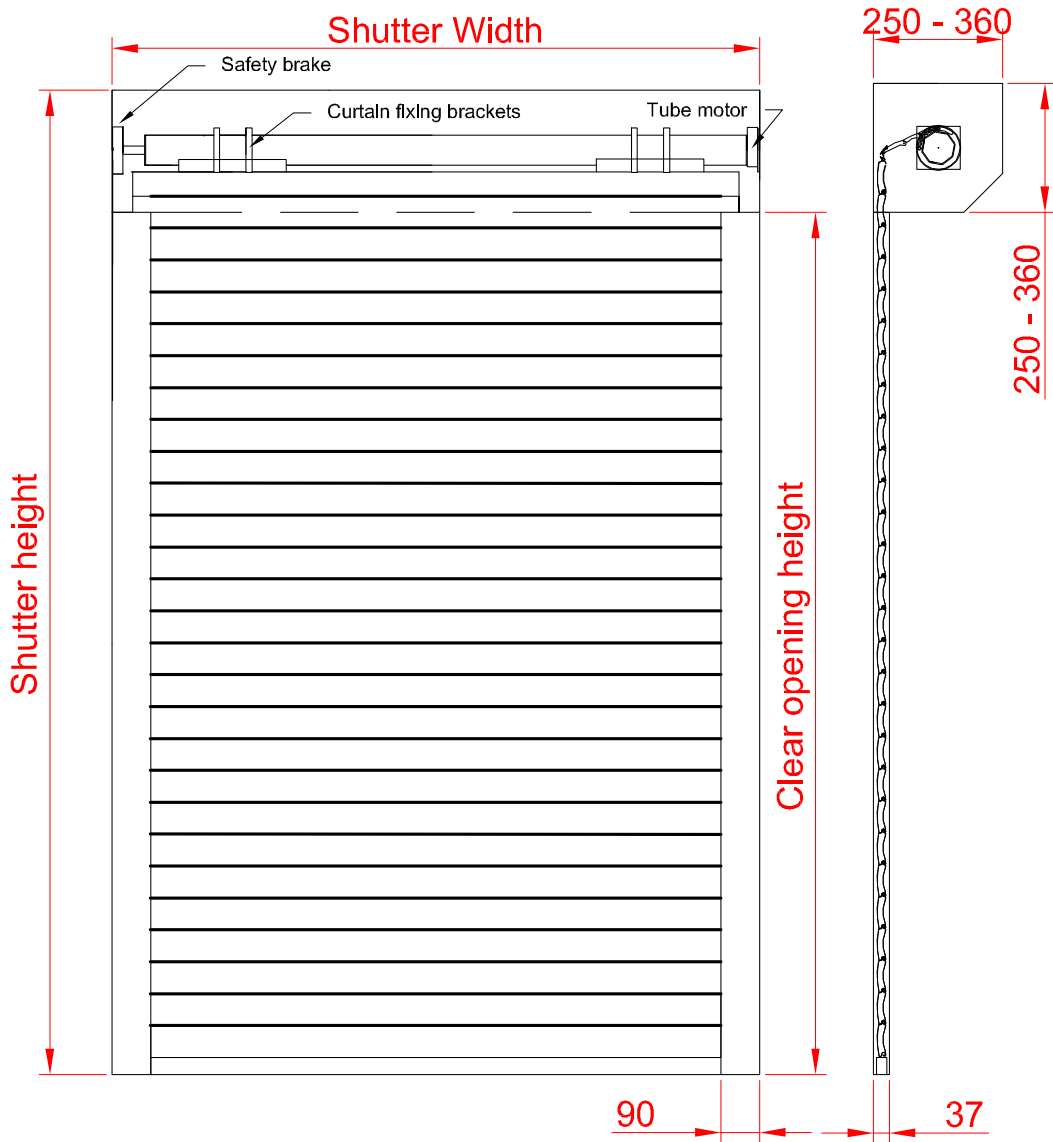

FIXING DETAIL

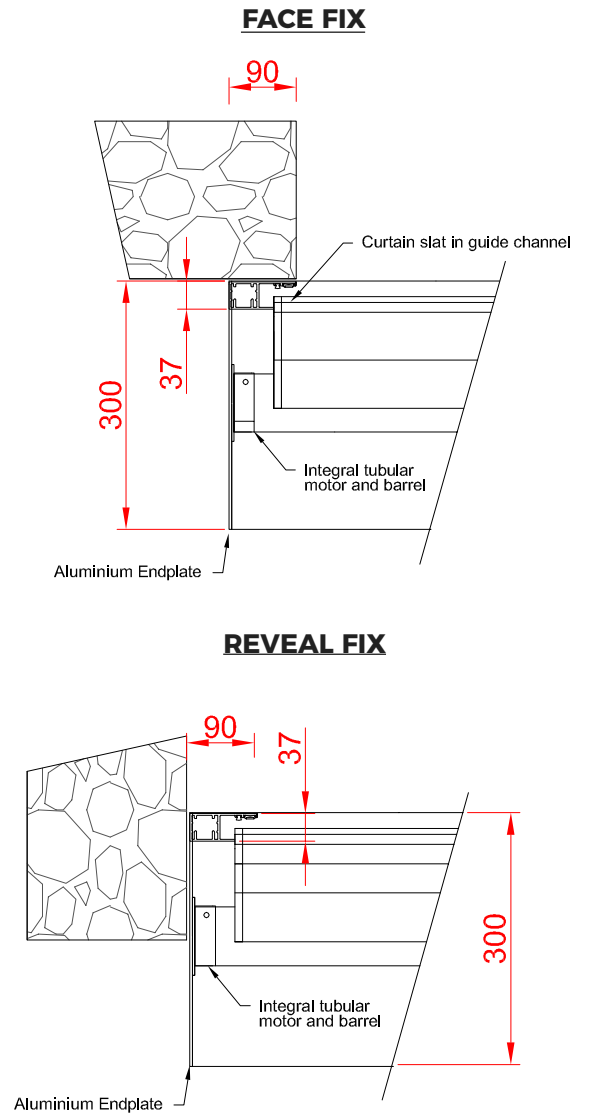

SLAT PROFILE

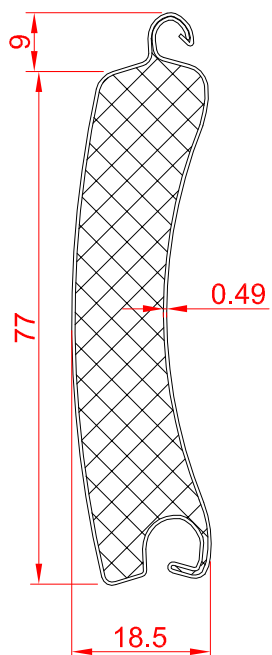

GUIDE CHANNELS

