



Insulated mild steel security shutter suitable for industrial and commercial sites. Maximum area of 22m² with a tubular motor and 35m² with an outboard motor. Rapid rise option also available with a Frequency Inverted motor.



APPLICATIONS

Industrial and commercial sites requiring large aperture coverage, and improved insulation properties from the shutter. Ideal for rapid rise / fast action opening and closing when in conjunction with Frequency Inverted motor.

CURTAIN SLAT

Double skinned 95mm steel slat with polyurethane insulating core.

Finish: Galvanised as standard. Powder coating and Plastisol laminated finishes available on request (surcharges apply).

| | |
|----------------|---|
| Weight per m2: | 12.8kg |
| Maximum Width: | 7000mm (tubular) 8000mm (outboard) |
| Maximum Area: | 20m ² (tubular) 35m ² (outboard) |
| Slat U-Value: | 1.1 W/m ² K |

CASING

Galvanised steel casing & end plates as standard.

Finish: Galvanised as standard, powder coating available on request (surcharge applies).

| Guide Height (mm) | Plate Size (mm) | Motor |
|-------------------|-----------------|----------|
| 2195 | 355 | Tubular |
| 3250 | 400 | Tubular |
| 4000 | 450 | Tubular |
| 3250 | 400 | Outboard |

| | | |
|------|-----|----------|
| 4000 | 450 | Outboard |
| 5000 | 500 | Outboard |
| 6000 | 550 | Outboard |

Plate sizes shown as a guide only and may vary. Note that outboard motors are generally larger than the plate itself.

BOTTOM SLAT

Extruded aluminium bottom slat with weather seal.

GUIDE CHANNELS

Steel guide channels with brush seals. Width of 80mm as standard.

Finish: Galvanised as standard, powder coating available on request (surcharge applies).

OPERATION

Electric, Tubular Motor: Tubular motor with key switch or outboard motor with push button control.

Electric, Outboard Motor: Three phase motor with push button control station as standard. Motors can be direct drive, inboard or outboard design. Final design will be project specific but all motors incorporate a chain manual override facility. Numerous options such as group or remote control etc., available as required. Safety peripherals (i.e., safety edge, photo-electric cell, etc.) will be required for automatic closing or high-speed operation).

CE compliant to all applicable directives and regulations.

FRONT FACE

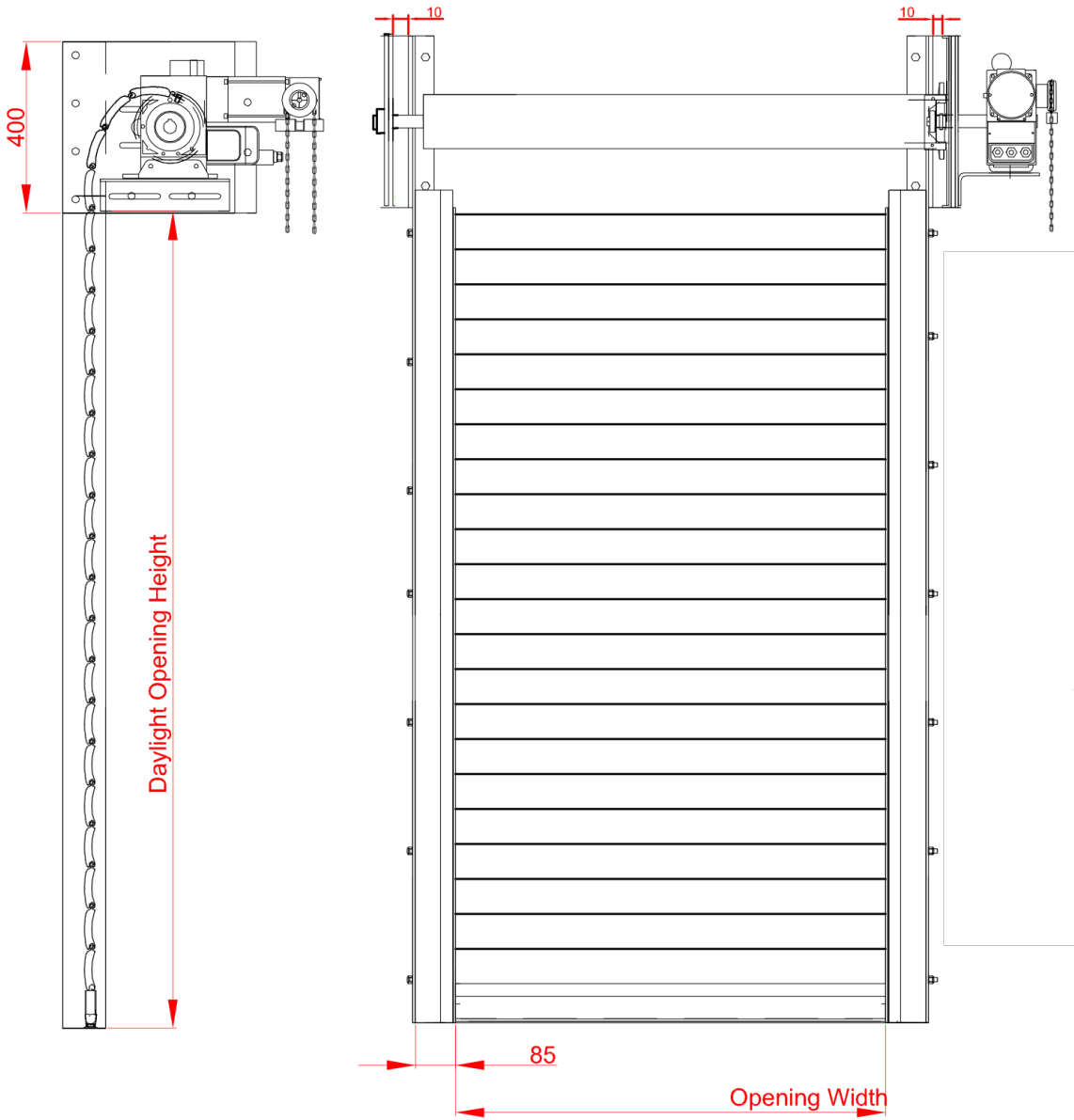

FIXING DETAIL

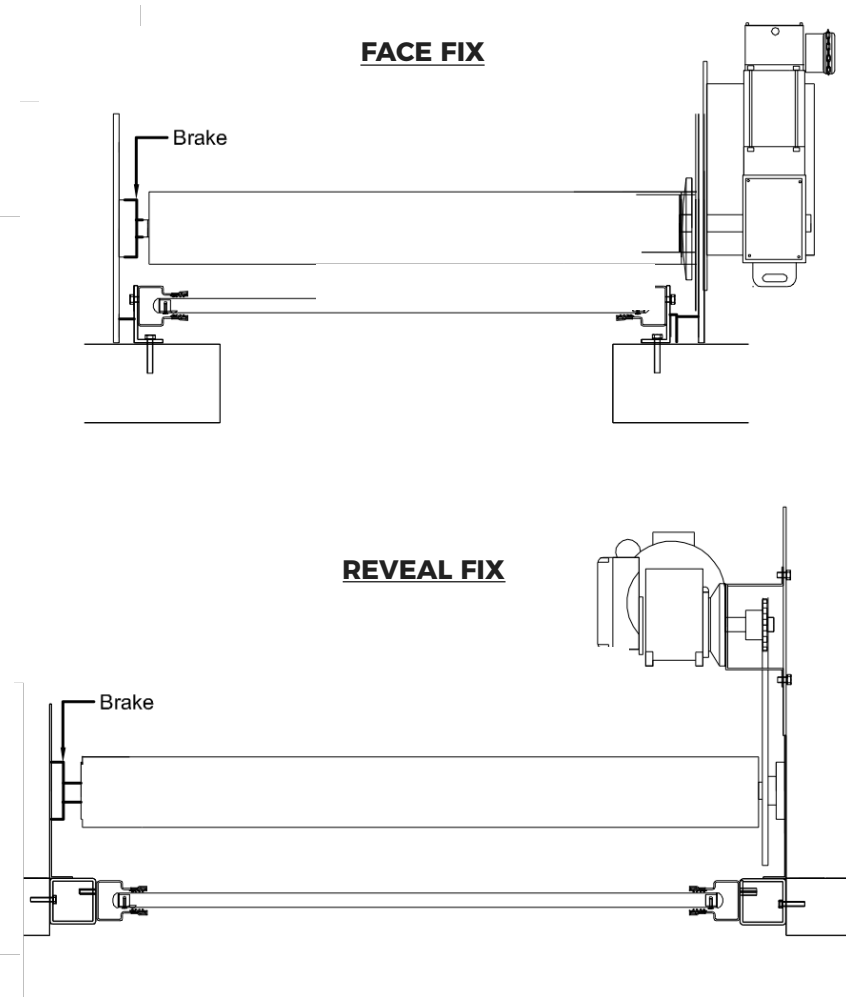

SLAT PROFILE

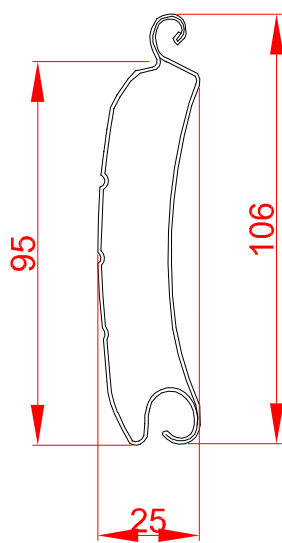

GUIDE CHANNELS

