

# DIAMOND X /S

## DIAMOND X / S :: TECHNICAL DATASHEET



Diamond X & S retractable security grilles are an excellent deterrent against opportunist intruders and offer cost effective protection in lower risk areas. Often used in the home to protect you and your valuables, they are also installed in other light commercial premises, such as shops, care homes and student accommodation.



### APPLICATIONS

A basic level of resistance and a good deterrent to opportunist crime. Will protect doors and windows in a domestic or light commercial setting.

### STANDARD FEATURES

- Traditional X or curved S shaped lattice with discreet stacks
- Bottom rolling design
- High security locking system
- Anti-jemmy security strip
- White RAL 9016 colour finish
- Hook deadlock

### OPTIONS

- Single or double grid design
- Hinged & lift out bottom track for doorways
- Swivel return stack
- Alternative RAL colours

### QUALITY

A high build quality and meets ISO 9001:2008. No visible rivets, maintenance free.

# DIAMOND X / S

## DIAMOND X / S :: TECHNICAL DATASHEET

### FRONT PROFILE

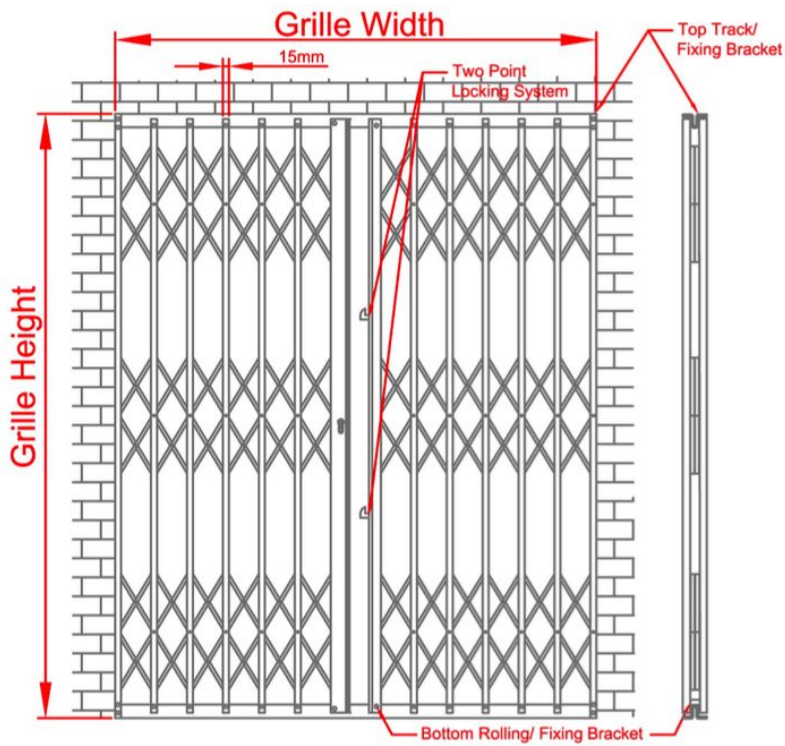

### REVEAL FIX

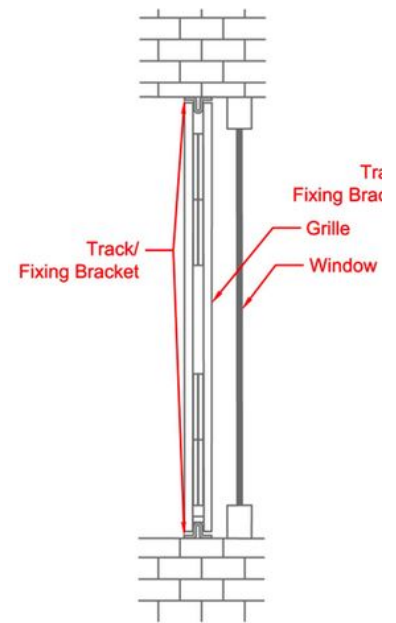

### GRILLE PATTERN

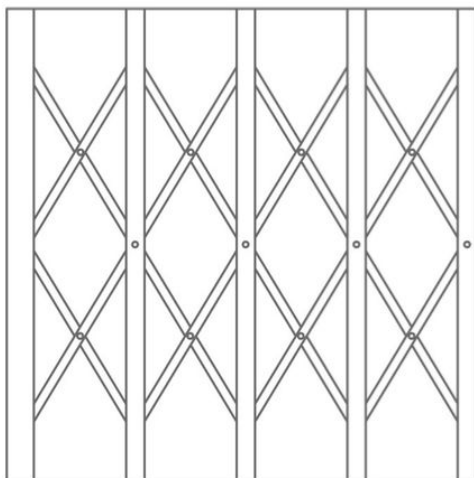

### FACE FIX

